

Taking and Drawing a Family History

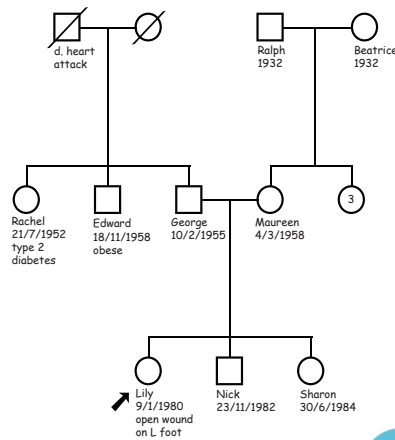

learning
genetics
teaching
education
resources
clinical health
practice

Project Team

Professor Peter Farndon
Ms Michelle Madeley
NHS National Genetics Education and Development Centre

Ms Erin Harvey
NCHPEG (National Coalition for Health Professional Education in Genetics)

© 2008 NHS National Genetics Education and Development Centre

This publication may be photocopied for non-commercial purposes for healthcare staff.

First published 2008
Birmingham: NHS National Genetics Education and Development Centre

ISBN 978-0-9556680-5-0

Copies available from:
The NHS National Genetics Education and Development Centre
Morris House
c/o Birmingham Women's NHS Foundation Trust
Edgbaston
Birmingham
B15 2TG
Phone: 0121 623 6987
www.geneticseducation.nhs.uk



Introduction

This pack of factsheets about collecting and recording a genetic family history is one of a series of resources developed by the NHS National Genetics Education and Development Centre to support health professionals in undertaking genetic activities in clinical practice.

This sheet may be photocopied for non-commercial education purposes for healthcare staff and you are welcome to use the pack or individual sheets to share with colleagues or to use within your teaching. The series can be downloaded from our website www.geneticseducation.nhs.uk along with a range of other support material.

Further series of factsheets on understanding modes of inheritance and interpreting family patterns of medical conditions are in preparation.

Contents include:

- Part 1:** Key points for taking and drawing a genetic family history
 - Part 2:** What is a genetic family history?
 - Part 3:** Why is taking a genetic family history important?
 - Part 4:** What are the accepted symbols to use in drawing a pedigree?
 - Part 5:** What and how much information should be included in a pedigree?
 - Part 6:** Gathering information and drawing a genetic family tree
 - Part 7:** Pedigree drawing exercises
 - Part 8:** Safeguarding the information in a genetic family history
- Test your knowledge: a family history puzzle
Cancer scenarios

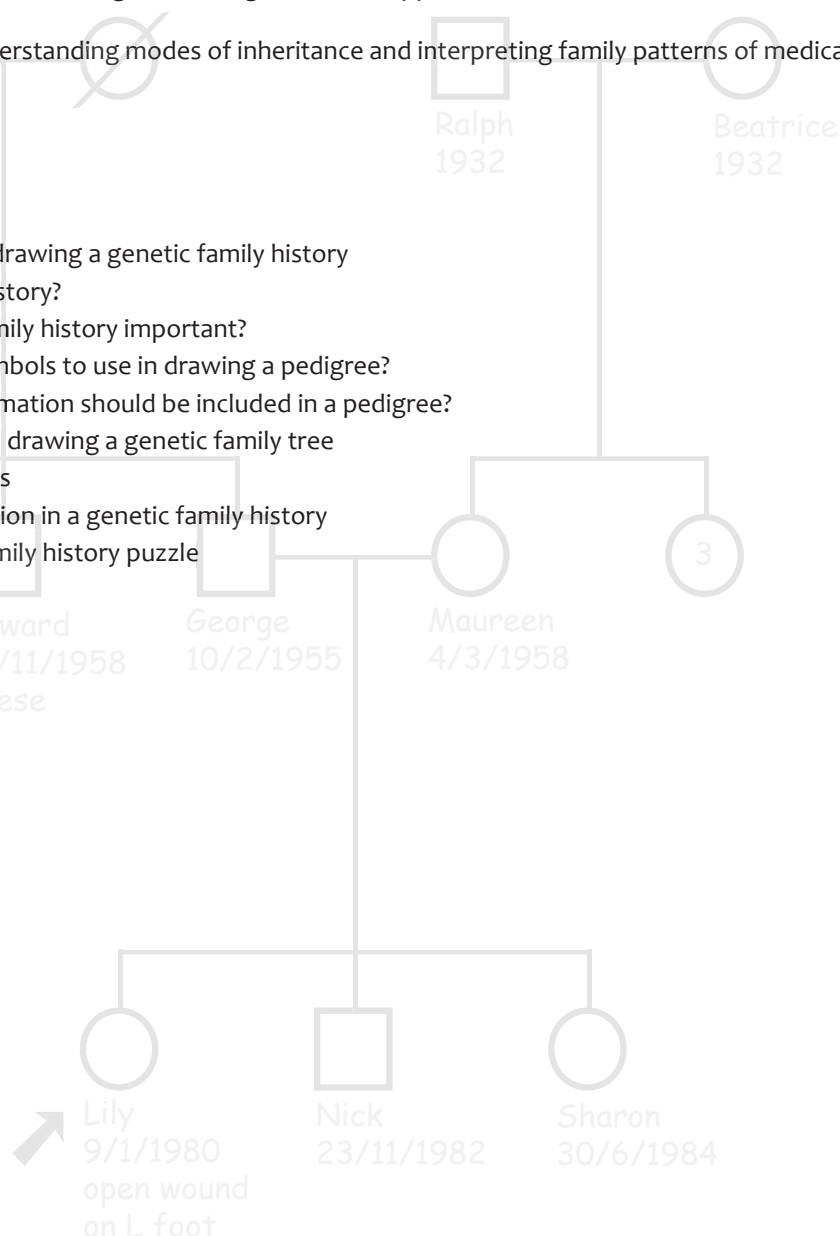



Key points for taking and drawing a genetic family history

Taking and drawing a genetic family history may involve asking for information on many members of a family, or may be targeted to detect a family pattern of a particular condition, according to the clinical question. The basic approach is the same – collecting information about relatives and their partnerships in one generation before moving up or down a generation.

This factsheet is a summary of our series on “Taking and drawing a family history” which offers more information and detailed explanations. The series includes, for example, factsheets on how to decide what and how much information is needed, the questions to ask and how to build up a detailed pedigree step by step. It is important to be sensitive when asking questions about illnesses and relationships in the family.

Key questions about family members

Although it may be best to take a systematic approach to enquiring about each branch of a family, sometimes this may not be possible in a busy clinic. There are some useful general questions, however, to gain a quick overview of medical conditions in a family. Answers to these questions may trigger a need for drawing out how the people with the condition are related to each other, to inform a preliminary assessment of whether there is an increased genetic risk which warrants further investigation or specialist referral.

Key questions

- “Do you have any concerns about diseases or conditions that seem to run on either your or your partner’s side of the family?”
- “Does anyone have a major medical, physical or mental problem?”
- “Has anyone ever needed treatment in hospital? Has anyone ever had any serious illnesses or operations? How old were they at diagnosis?” (Avoid just asking “Is everyone well?” as past medical history may not be offered!)
- “Have any adults, children or babies died? How old were they and what was the cause of death? Have there been any miscarriages or babies who were stillborn?”

Each specialty will also have key questions about symptoms and signs which would alert the clinician to the possibility that a genetic condition might be present in a family.

Tips for taking and recording a genetic family history

On the next page we outline the key steps in taking a genetic family history. In the family shown, the people giving the information are your patient and her husband. We have highlighted the different branches of their families and numbered them. Recording details of relatives in this order works well in practice: ask about partners, children, brothers, sisters and parents, moving across and then up/down the generations. This is set out overleaf.

Steps in taking and recording a genetic family tree - branch by branch

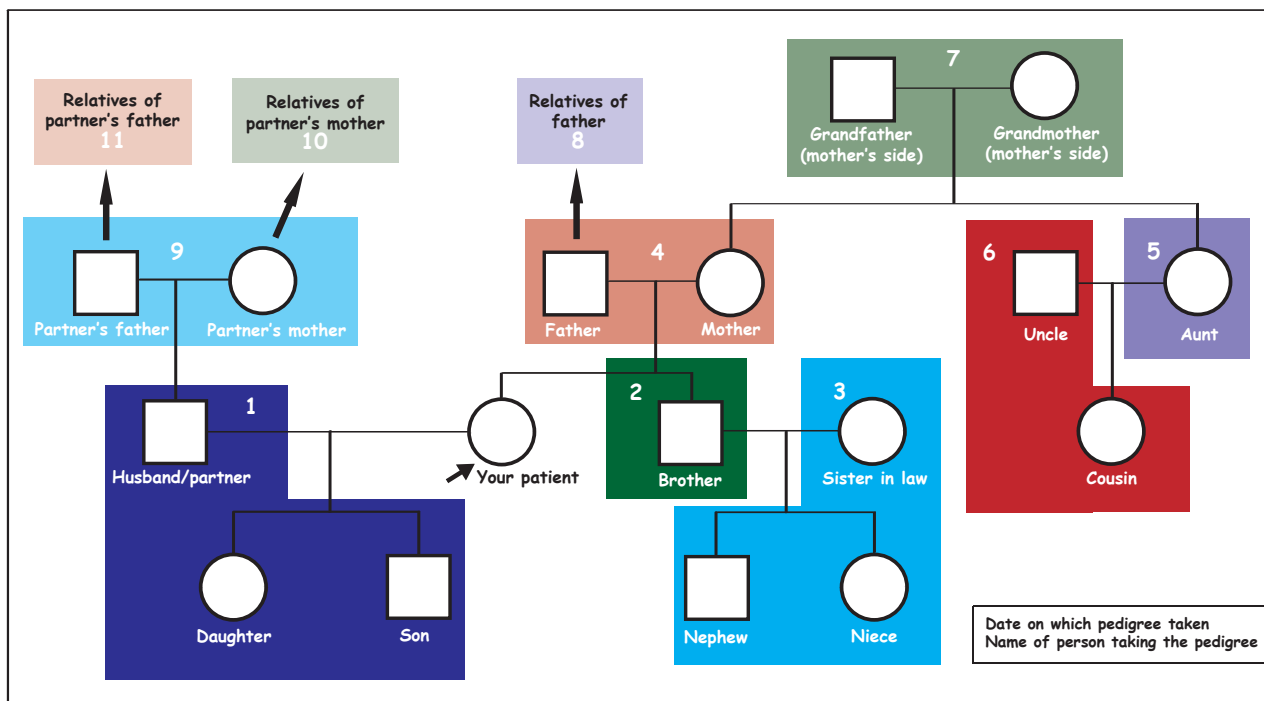

Fig. 1 How to record information about the family - branch by branch

- Ask about your informant and his or her partner(s) and their children (Branch 1).
“How many children have you had? Have you lost any children?”
“Are all your children with the same partner or were any with previous partners?”
- Next ask about each brother and sister of the informant (Branch 2), his or her spouse(s) and their children (Branch 3). Remember to ask if any have died, or were lost during pregnancy.
- Record details about the parents of your informant (Branch 4).
- Choose one of the parents (usually the mother). Record details of each of the person’s brothers and sisters (Branch 5) and their children (Branch 6).
- If you need to gather information about your patient’s grandparents (Branch 7) collect it now.
- Then ask the same questions about relatives of the other parent, usually the father (Branch 8).
- Now return to your informant’s partner and collect information about his/her relatives - brothers and sisters and parents (Branch 9).
- If you need information about the relatives of parents of the partner, choose one – usually the mother first (Branch 10). Having collected information, then ask about the relatives of the father of the partner (Branch 11).

At the end,

- Thank the informant, and ask: *“Is there anything else you think I should know that I haven’t asked about?”*
- Date and write your name legibly on the pedigree. Add an explanation of any abbreviations.
- Ask for consent to share family history information with colleagues and/or other family members and note this.

What is a genetic family history?

Information from a family tree can be important in making diagnoses and assisting clinical management. This series of factsheets focuses on the knowledge and skills required to take and record genetic family histories.

What is a genetic family history?

A genetic family history consists of information about

- the biological relationships between family members and
- any medical conditions they may have.

Although the information can be written as text, the family history is usually recorded as a family tree (pedigree) which allows a pictorial representation of family relationships and those family members affected by medical conditions.

The information is usually collected during a clinical consultation, and used to draw the family tree in the presence of the person giving the information (Fig. 1).



Fig. 1 Taking a family tree

There is international agreement that standardised pedigree symbols should be used, to ensure that health professionals throughout the world can share, understand and interpret family history information (Fig. 2). It is therefore useful for health professionals to be able to “read” a pedigree, even if their roles do not include taking family histories regularly.

There are other ways of collecting family history information; for instance, the patient or family may agree to complete a family history form. However, most health professionals find it easier to gain an overview through visual representation in a pedigree.

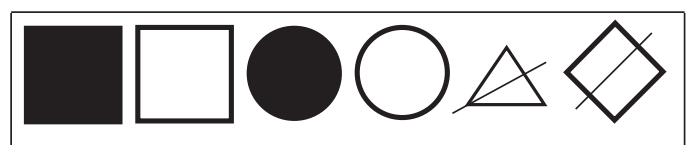

Fig. 2 Standardised pedigree symbols

Other factsheets in this series

This sheet is part two in the ‘Taking and Drawing a Family History Series’. All are based on clinical experience. They include:

- Why is taking a genetic family history important?
- What are the accepted symbols to use in drawing a pedigree?
- What and how much information should be included in a pedigree?
- Gathering information and drawing a genetic family tree.
- Pedigree drawing exercises.
- Safeguarding the information in a genetic family history.

Further support

The NHS National Genetics Education and Development Centre is developing materials to support health professionals whose roles include taking and recording family history information.

In addition to this toolkit, there are resources on:

- different modes of inheritance
- pedigree patterns associated with them
- clinical information about genetic conditions likely to be met in practice.

Video clips showing pedigrees being taken in practice will be available later in 2008. Resources are available free for non-commercial education purposes for healthcare staff on the Centre's website www.geneticseducation.nhs.uk

Why is taking a genetic family history important?

With the exception of conditions resulting from accidental trauma, every disease has some genetic component.

The strength of the genetic component in a family may be apparent by the number of people affected by a particular condition. This is why taking a family history is important.

A positive family history can be an important risk factor for asthma, diabetes and certain forms of cancer and can identify families with known single-gene disorders. Some UK national clinical guidelines therefore highlight the importance of taking a genetic family history.

If the family history is not considered, clinically meaningful information might be overlooked. In clinical management, information from the family tree can be just as important as information from a laboratory test.

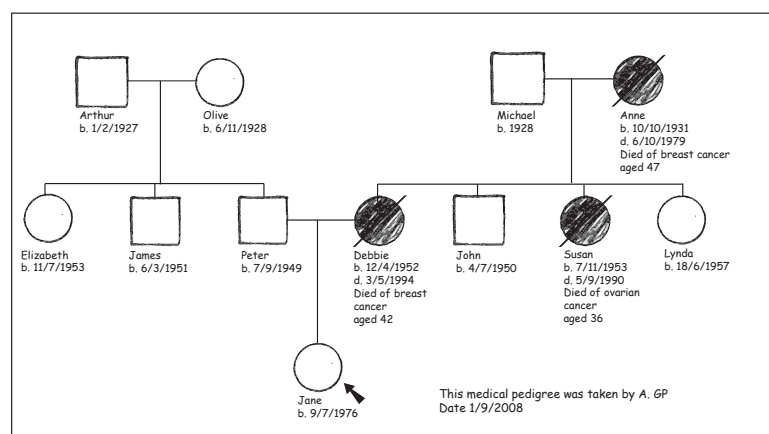

Fig. 1 Example of a family tree

Some further benefits of taking a family history are highlighted below:

The genetic family history can reveal patterns of inheritance

Patterns of inheritance can often be easily visualised in a family in the form of a pedigree. Recognising a pattern of people with a particular condition may suggest an underlying type of inheritance. The pattern may also help to distinguish between conditions with similar presentations because they are known to have different modes of inheritance.

The genetic family history may help make or refine a diagnosis

Considering similar or related symptoms which occur in several members of a family may reveal that in fact they are all features of one unifying diagnosis. Understanding the variability in a family may allow earlier diagnosis in some family members, especially important if early surveillance and treatment have been shown to be of value. This applies particularly in some autosomal dominant disorders which have variable expression (such as Marfan syndrome, neurofibromatosis type 1 or forms of osteogenesis imperfecta).

The genetic family history helps assess the likelihood of genetic disease in relatives

Genetic information is family information. If a family history is not taken, a patient's relatives are less likely to be considered; the half brother, aunt, or pregnant cousin who may also have a genetic risk and so be prone to certain medical complications may not be identified.

The genetic family history can affect testing, treatment and management strategies

Family history information is needed to identify appropriate family members with a close biological relationship to the affected person so that treatment or management guidelines can be offered and implemented as appropriate. Individuals who may benefit from genetic testing may also be identified from the family history.

Guidelines for investigation, management and surveillance (for instance colonoscopy or mutation analysis for inherited bowel cancer) can thus be instituted for other family members who may have been identified to be at risk.

The genetic family history may highlight the need for referral for specialist opinion

Where someone has been identified as being at higher risk as a result of their family history, it may be appropriate to refer the patient for specialist opinion (such as a suspected diagnosis of Marfan syndrome). Details about the pattern of disease and affected members will be valuable information for genetic and other specialists.

Taking the genetic family history helps in building rapport with patients

In addition to having medical benefits, eliciting genetic family history information creates opportunities for the patient and provider to develop trust, to ask questions, and to correct any misconceptions about a symptom or illness. Since the family history is easily updated to reflect births, deaths, and other major events in a family, it will also grow with time.

What are the accepted symbols to use in drawing a pedigree?

Standardised symbols for drawing pedigrees have been adopted internationally. This helps to ensure that health professionals throughout the world can share, understand and interpret family history information. It is therefore useful to know about and be able to “read” a pedigree, even if a health professional’s role does not include taking family histories regularly.

The pedigree symbols for individuals (Fig. 1) need to be connected together to show family relationships. Drawing lines between pedigree symbols correctly (Fig. 2) is the key to a good pedigree.

	Male	Female	Sex Unknown
Individual			
Affected individual (symbol coloured in)			
Multiple individuals			
Deceased			
Pregnancy			
Miscarriage			
Person providing pedigree information			

Fig. 1 Examples of most commonly used pedigree symbols

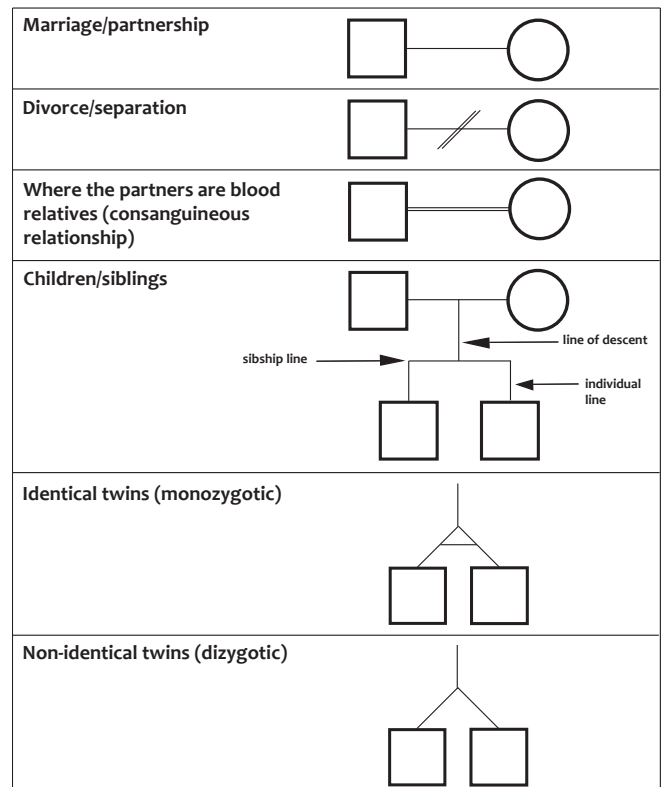

Fig. 2 Examples of relationship lines

Drawing a pedigree, step-by-step

The following is an example of a small family to demonstrate how pedigree symbols and relationship lines are drawn. A pedigree usually contains additional information about family members as is shown on factsheet 6.

Your patient, Nigel has three children and a grandson. Draw the symbol for Nigel, then his wife, Margaret. Traditionally, women are placed to the right of their partners in a pedigree (Fig. 3).

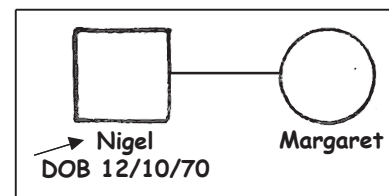

Fig. 3

Next, add Nigel and Margaret's three children, Harry, Mary, and Elizabeth. Draw a straight line down from the centre of the relationship line between Nigel and Margaret. Then add what looks like a comb, with three teeth pointing down and the symbol for each child attached (Fig. 4).

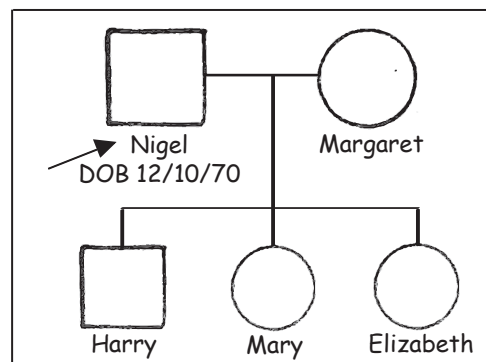

Fig. 4

Nigel and his middle daughter, Mary, both have achondroplasia (a form of restricted growth). To indicate the condition, shade in their symbols and include a key. Mary has a son, Sam, who also has achondroplasia, so you add him and his father, James, to the pedigree (Fig. 5).

This three generation pedigree shows that the condition is being passed down the generations. The pattern is consistent with an autosomal dominant mode of inheritance.

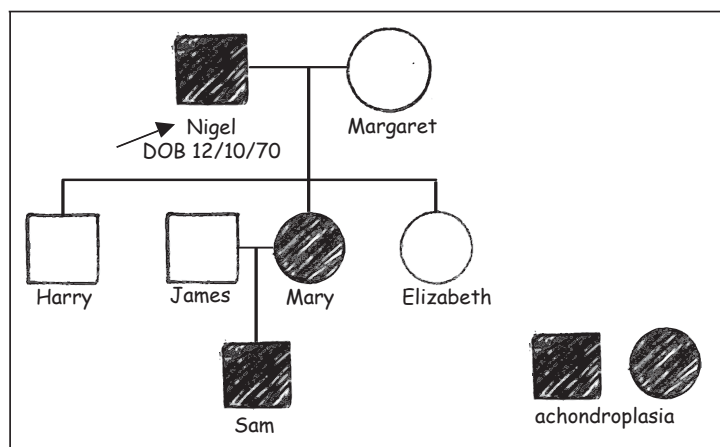

Fig. 5

It is important that the person recording the family history ensures that it reflects accurately the information given by the patient. One must recognise that the accuracy of the diagnoses given will depend on how much knowledge is shared within the family, and accuracy of an individual's recall. The purpose of this toolkit is to assist in the accurate recording of family history details. The accuracy or completeness of the information is something to be considered when the pedigree needs to be interpreted for clinical management, and is the subject of a separate set of factsheets.

What and how much information should be included in a pedigree?

How can one decide how much information needs to be gathered, and from whom? The key is to identify the purpose for taking the family history.

Sometimes we may want to ask questions targeted to identify specific family members rather than take a family history about all medical conditions. This could be to:

- identify people at a higher probability of being a carrier or of having a genetic condition already known in the family
- offer carrier testing to other family members as a result of the antenatal or neonatal screening programmes.

At other times, we may want to ask more general questions about medical conditions to build up a detailed picture of the family history to identify:

- whether there are any genetic disorders in a family
- the number of people with disorders such as diabetes, cardiovascular disease or cancer to use the family history as one of the risk factors when offering advice to an individual about prevention
- those families with common disorders (e.g. breast or colorectal cancer) where a single gene disorder may be predisposing to the condition. This is so that individuals can be offered targeted surveillance.

How many generations should we include?

If in doubt, aim for the usual practice of three generations, particularly to build up a full picture of illness in a family, or to try to deduce a mode of inheritance from the pattern of affected family members.

Asking about only two generations or more than four may be appropriate depending on the genetic basis of the condition and family size.

How many people should we include?

The minimum should be to gather information on first degree relatives (children, siblings and parents) of an individual. This may be sufficient to inform a clinical decision, but equally you may need to supplement this with information about other relatives. This may often be necessary to inform a view about reassurance or referral to a specialist.



Key information helpful for drawing a genetic family history (pedigree)

A very brief overview of the types of information often required now follows. Specific questions to elicit this information, and how it can be shown on the pedigree are the subjects of factsheet 6.

For each key person, record under the pedigree symbol the following information as appropriate:

- Name
- Date of birth (DOBs are preferable to current ages or estimates)
- Relevant symptoms and/or diagnoses and age at diagnosis (if known)
- Cause of death and age at death (if known)

The previous factsheet showed how pedigree symbols can be connected together to show family relationships. Here are two examples (Fig. 1 & Fig. 2) to show how medical information can be presented in a pedigree. Note that no pedigree is complete without the name of the person who took it, the date it was drawn, and an explanation of any abbreviations.

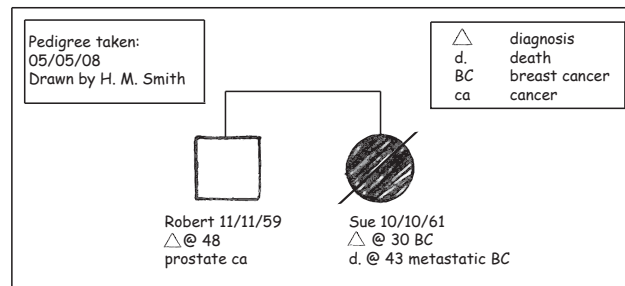

Fig. 1

This pedigree (Fig. 1) immediately highlights relevant medical information for Robert and his late sister, Sue. It should trigger questions about the occurrence of cancer in other family members.

Depending on the medical condition in the family, it might also be appropriate to ask about:

- Pregnancy and birth history
- Developmental delay and learning disabilities
- Dysmorphic features/congenital anomalies
- Occupational/environmental exposures
- Operations and hospitalisations
- Medications.

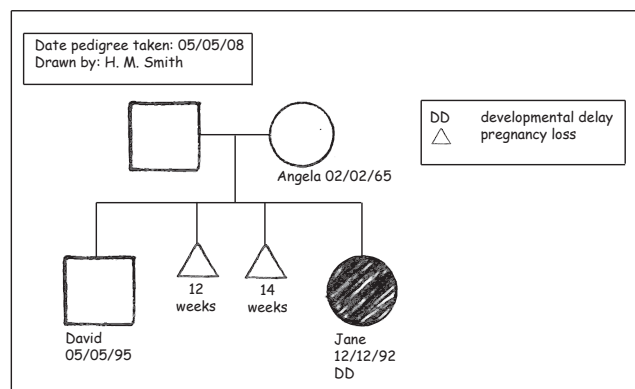

Fig. 2

This pedigree (Fig. 2) should trigger questions focussing on developmental delay in any nieces or nephews, recurrent pregnancy losses in other members of the family, or if any diagnostic and/or genetic tests have been performed.

Gathering information and drawing a genetic family tree

How can busy health professionals gather family history information in an efficient way? This factsheet outlines a set of questions, found useful in clinical practice, which if asked systematically will help to ensure that important information is recorded. A family tree will be built up on the following pages by using the questions.

Most people are happy to collect together the required information (often consulting other family members) if they are informed before attending a clinic. When asking for family information, please remember that some people may feel guilty or ashamed that they could have “passed on” an altered gene for a serious condition to another family member. Also, as people may have had recent bereavements, please enquire as sensitively as possible.

General questions to gain a quick overview of a genetic family history

Each specialty will have key questions about symptoms and signs which would alert the clinician to the possibility that a genetic condition might be present in a family, but the following are helpful in quickly gaining an overview.

“Do you have any concerns about diseases or conditions that seem to run on either your or your partner’s side of the family?”

“Does anyone have a major medical, physical or mental problem? Has anyone ever needed treatment in hospital? Has anyone ever had any serious illnesses or operations? How old were they at diagnosis?” (Avoid just asking “Is everyone well?” as past medical history may not be offered!)

“Have any adults, children or babies died? How old were they and what was the cause of death? Have there been any miscarriages or babies who were stillborn?”

The minimum information required for a targeted family history

- Draw the siblings, children and parents (first degree relatives) of your informant, and their names, dates/year of birth and any significant illnesses.
- It may not be necessary to record names of members of the extended family although it may be important to show how many unaffected people there are in the family.



Drawing a family tree

Karen Hill has been diagnosed at the age of 35 as having breast cancer. As there are other cases of cancer in her family history, she is concerned about the chances of her children developing cancer.

The first step is to build up a family tree to appreciate the relationships of the people with cancer, which will now be illustrated, step by step. The parts of the pedigree newly drawn as a result of the next set of questions will be shown in red.

1. Start with the person giving the information (informant)

Use a pen (not a pencil) as you are writing a medical record. A pedigree drawing template (such as that devised by the NHS National Genetics Education and Development Centre) can be helpful to achieve uniform symbols.

Start at the bottom or top of the page according to whether you will be developing the tree “upwards” from a child, adding parents, aunts, uncles and grandparents, or “downwards” if the informant is a grandparent. The plan should be to move systematically through the family relationships, usually recording partner, children, brothers, sisters and parents moving across and then up/down the generations. *“Please may I ask if either of you come from large families with many brothers and sisters or aunts and uncles?”* If so, consider rotating the page and drawing in landscape format.

Draw the symbol appropriate for the gender of your informant

Karen Hill has been diagnosed as having breast cancer at the age of 35 years (Fig. 1).

- Mark your informant with an arrow.
- Write in her or his name and date of birth and medical information.
- Consider asking about occupations and environmental exposures if appropriate to the condition.

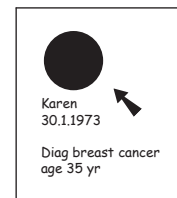

Fig. 1

Now ask about partner

Karen is married to Andrew (Fig. 2).

“Are you married; or do you have a partner?”

“Have you been married before or had any previous partners?”

Be sensitive when trying to determine if partners are related by blood (a consanguineous relationship).

Questions may include:

“Are you and your partner related (except by marriage)?”

“Are there any surnames or maiden names in common in the family?”

“Did any couples in the family have the same surname before they were married to each other?”

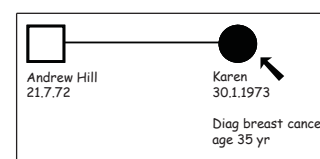

Fig. 2

2. Ask about the children of the person giving the family history

Karen and Andrew have a son and two daughters (Fig. 3).

“How many children have you had? Have you lost any children?”

“Are all your children with the same partner or were any with previous partners?”

“Please give me the names of your children, and their dates of birth in order of their ages, starting with the eldest first.”

If possible draw the firstborn on the left.

If there is a current pregnancy, record the date of the last period (LMP) or expected date of delivery (EDD).

For some conditions, it may be appropriate to ask about miscarriages, stillbirths or deaths in each partnership. Some people may find this upsetting. Being open often helps:

“Have you lost any children?”

“Did you lose any babies or have any other pregnancies?”

Record the number of weeks for pregnancy losses (*“I am sorry to hear of your loss”* if it occurred recently). If a pregnancy was terminated (rather than lost spontaneously), sensitively ask if there was a medical reason.

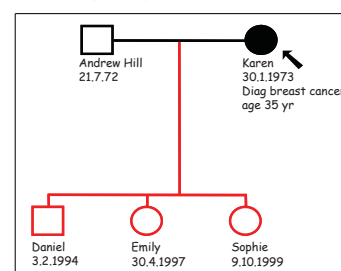

Fig. 3

3. Next ask about the siblings of the informant, their spouses and their children

Karen has a brother Paul, whose daughter Jessica is fit and well. Karen’s mother had a son (John) with a previous partner.

John has a daughter (Fig. 4).

“How many brothers and sisters do you have; have any of your brothers or sisters died?”

“Do they all share the same mother and father?”

You may need to draw in their parents at this stage to make the relationships clear.

“How many children have each of your brothers/sisters had?”

“Did they lose any children during pregnancy or in childhood?”

Ask about medical conditions.

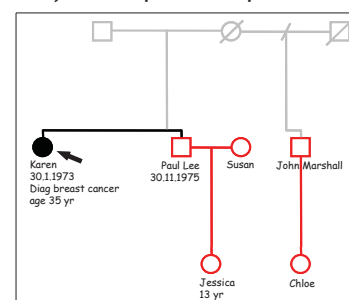

Fig. 4

4. Record details about one parent of your informant

Karen's mother Margaret Lee died at 62 yr with breast cancer; Karen wants to know if her daughters are at increased risk. Ernest, Margaret's first partner, died from lung cancer (Fig. 5).

Ask for name, date/year of birth and any medical conditions.

Do you need to collect details on the parent's brothers and sisters and their own parents?

Deciding how many generations to include usually depends on the reason for taking the pedigree.

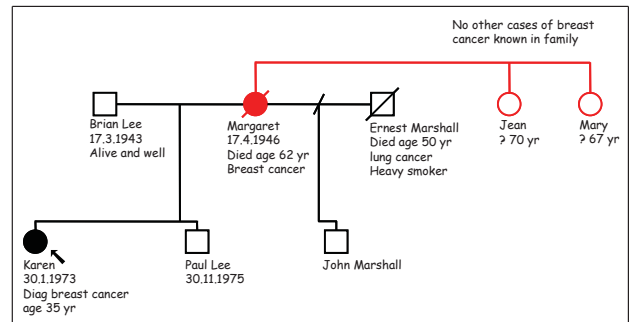

Fig. 5

5. Then ask about the other parent

Karen's father had three siblings, but Karen has no further details (Fig. 6).

Her side of the family is now complete.

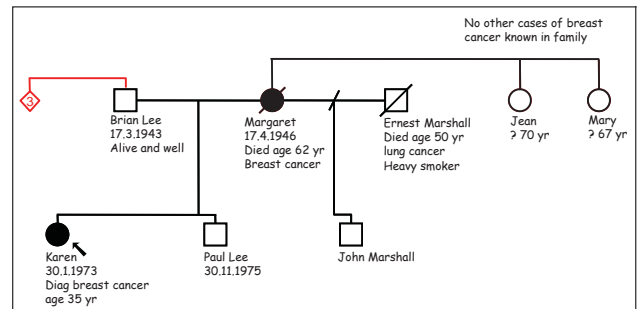

Fig. 6

6. Collect information about your informant's partner and his/her family

Return to Karen's partner, Andrew Hill, and collect information on his side of the family, working systematically through the generations using the same questions as before.

Andrew has a brother with haemophilia; their father has diabetes but their mother Patricia aged 52 is well. Her father died at the age of 24 years. He had had problems with excessive bleeding (Fig. 7).

To conclude

For some genetic conditions it is important to ask: "Originally, where did each of your grandparents come from?" This may help the laboratory target testing to specific gene alterations more common in certain populations.

As well as thanking the informant for the information, ask: "Is there anything else you think I should know that I haven't asked about?"

Most important last steps

- Date and write your name legibly on the pedigree together with an explanation of any abbreviations.
- Record the person giving the information (if you have not already placed an arrow next to their symbol).
- Always ensure that you have asked for permission to share family history information with colleagues and/or other family members and note this.

The completed family tree is shown on the next page, together with further tips about presenting information.

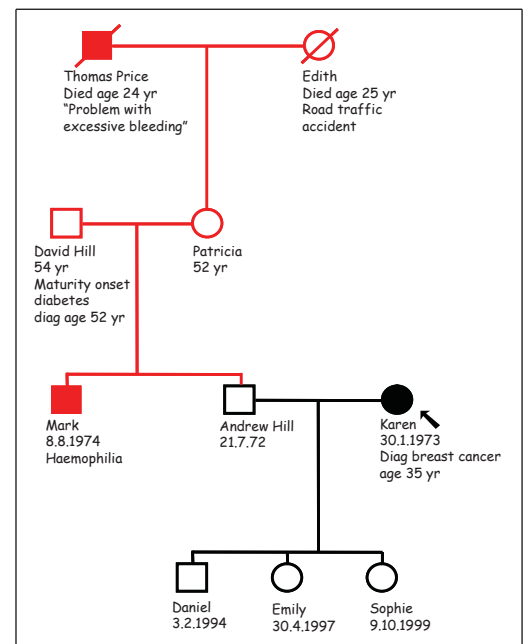
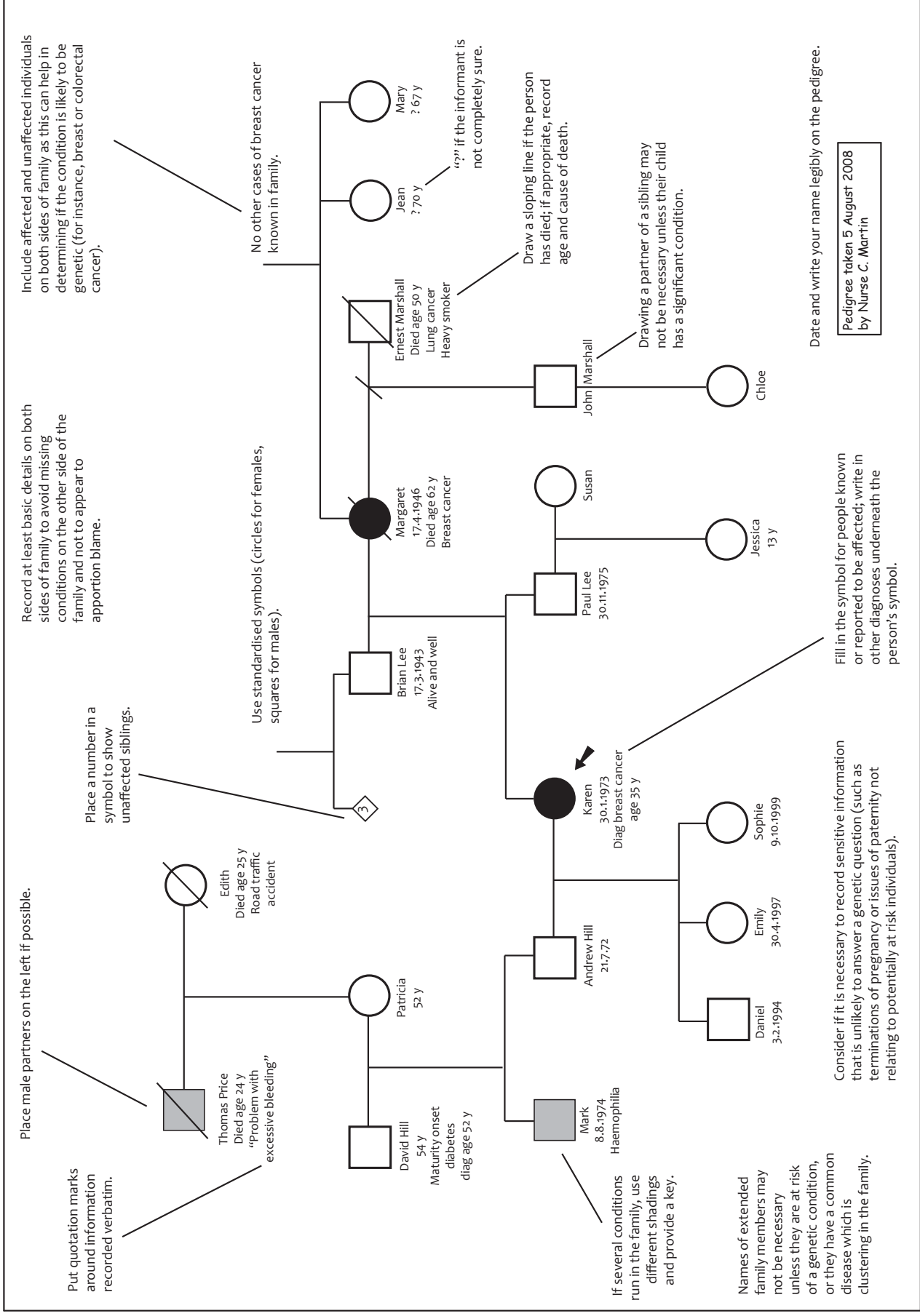

Fig. 7



Pedigree drawing exercises

The patient narratives below will give you an opportunity to practise drawing pedigrees.
The finished pedigrees are overleaf.

Family 1

Your patient, Anna, is 35 years old. She has a brother, Brad, who is 32. Anna and Brad are the only children of Charles, who died at 61 from cancer, and Nancy, who is alive and well at 57 years old. Anna is married to Don, who is 36, and they have identical 6-year-old twin boys, James and John. Brad and Linda have a 5-year-old daughter, Sarah, and a 2-year-old son, Michael. Brad and Linda are recently divorced.



Family 2

Lily is 28 years old (9.1.80). She has an appointment to look at a wound on her left foot that isn't healing well. Lily has a younger brother, Nick (23.11.82), and a little sister, Sharon (30.6.84). Lily's parents are George (10.2.55), who is obese, and Maureen (4.3.58). George's brother, Edward (18.11.58) is obese. George's sister, Rachel (21.7.52), has type 2 diabetes. George's parents are both deceased, and his father died of a heart attack. On her mother's side, she has three aunts who are all alive and well. Lily's maternal grandparents are Ralph and Beatrice, who both turned 75 in 2007 (so were born in 1932).

Family 3

Try drawing your own or someone else's genetic family history. Do you need to collect any additional information from other members of the family?



Pedigree 1

Drawn by: _____

Date: _____

For Pedigrees 1 and 2

- Did you remember to include your name and today's date on your pedigrees?
- Did you mark the person providing the pedigree information (your patient) with an arrow?
- Did you include individual names and dates of birth (or in this case current ages)?
- Did you connect siblings with a 'comb' pointing down?

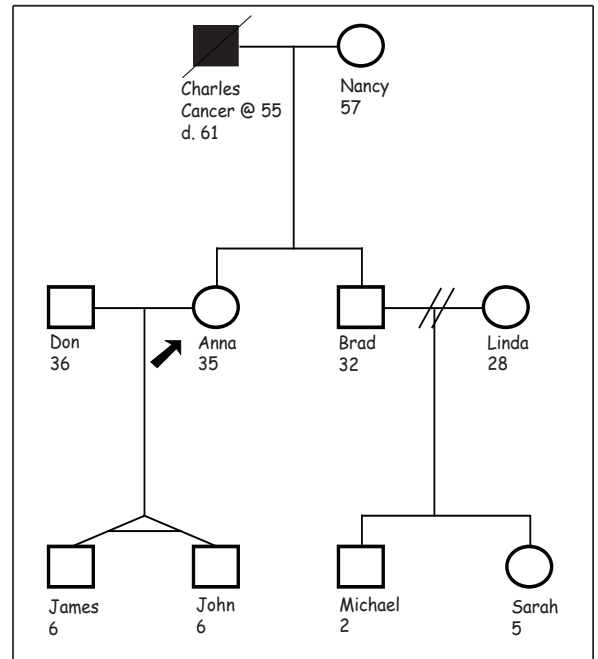

Fig. 1

Pedigree 2

Drawn by: _____

Date: _____

- In pedigree 1, did you connect the two individual lines for James and John to signify that they are identical twins.
- In pedigree 2, you may or may not have shaded in some of the symbols.
- What is important is that the relevant medical information is listed for each individual.
- In pedigree 2, if you shaded symbols or used abbreviations, did you include a key?

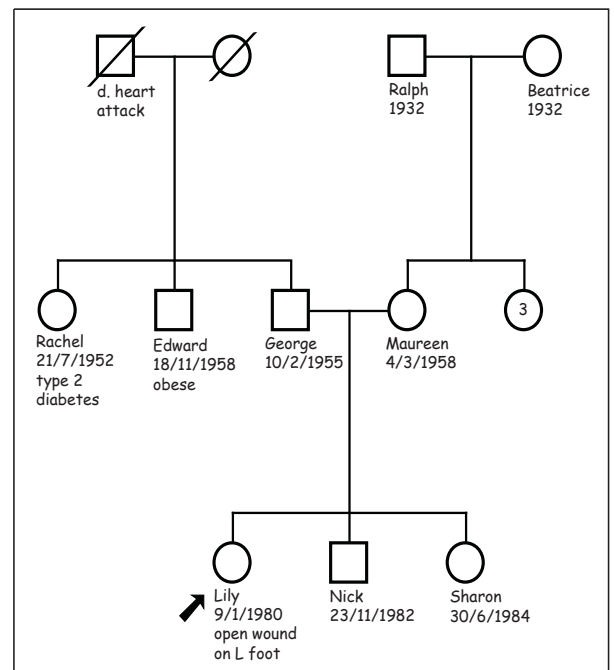

Fig. 2

Safeguarding the information in a genetic family history

A pedigree includes information about the biological relationships within a family, the medical diagnoses and genetic status of family members. This information is usually obtained from one member who gives it in good faith, using details obtained directly from other family members. Information about medical diagnoses in the family may well be known to many people, including friends and acquaintances. However, genetic family information should be held in confidence, but as it may be used to advise other family members it is good practice to gain consent from the person who gave the pedigree for information sharing and make a note of this.

The status of information from family pedigrees and its disclosure

Most individuals expressly state that they wish pedigree information and genetic test results to be available to other family members and professionals to assist in diagnosis and medical care.

Recording information about other people in a family (and passing it to health professionals) is permissible under the Data Protection Act (under Schedule 3) without the explicit consent of all those shown on the pedigree if the processing is necessary for medical purposes (including the purposes of preventative medicine, medical diagnosis, medical research, the provision of care and treatment and the management of healthcare services). This was the advice that The Joint Committee on Medical Genetics received from the Information Commissioner. The health professional should ask for and record consent that the pedigree may be shared with other members of the family if appropriate, and with other health professionals if necessary for the care of family members. If asked to release information, it is good practice to review the pedigree to try to ensure that only information relevant to the clinical purpose is released; for instance, it may not be necessary to give names on parts of the pedigree.

Publishing genetic family histories as part of clinical and research studies

Of course, consent from the person giving the pedigree needs to have been obtained. There are some other considerations to be taken into account, because the pedigree can give a great deal of information about biological relationships and health status. If it is imperative that a pedigree needs to be published, it is recommended that the minimum amount of information which needs to be disclosed is given on the pedigree figure. For instance, unless needing to demonstrate the precise pattern of males and females (affected and unaffected) and ages of onset in the family, is it necessary to signify the sexes and ages of family members? For relatively rare conditions, it may be possible for families to identify their family and also deduce not only their status but also that of other family members.

Reference

Consent and confidentiality in genetic practice: guidance on genetic testing and sharing genetic information (2005). Report of the Joint Committee on Medical Genetics. London: RCP, RCPATH, BSHG.

Confidentiality and consent are paramount



- Store the genetic family history information safely to preserve confidentiality.
- As it may be helpful in advising other family members, gain consent from the person giving the genetic family history, for information to be shared with family members and health professionals.



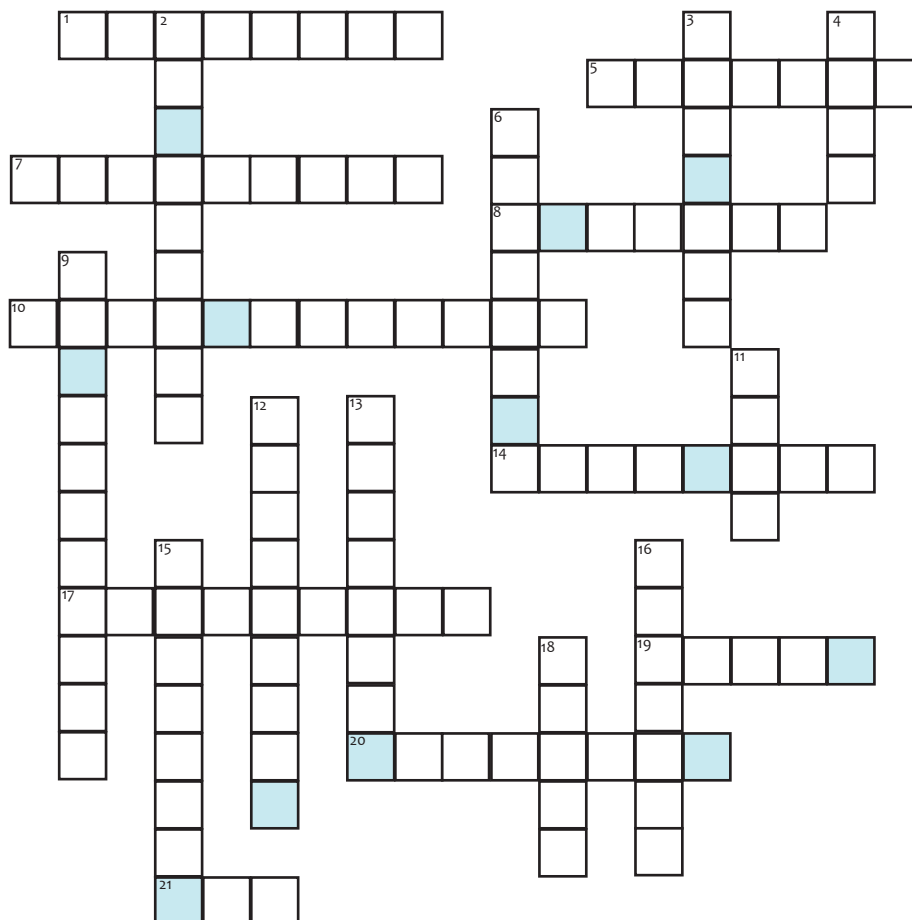



Test your knowledge: a family history puzzle

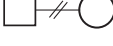

Across

1. A pictorial representation of a genetic family history (8)
5. If a condition is inherited, it must be caused by an alteration to the ___ material (7)
7. This symbol represents a ___ (9) 
8. Taking a family history can help to build up ___ with a patient (7)
10. The individuals joined by the double line are related as ___ (5, 7)
14. These individuals are ___ (8) 
17. These twins are ___ (9) 
19. The standard number of generations to include in a family history (5)
20. This couple is ___ (8) 
21. The molecule of life (3)

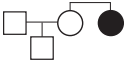
Down

2. Taking a family history may result in the earlier ___ of a condition (9)
3. The sex of the person in 7 across is ___ (7)
4. The assessment of this can be informed by details from a genetic family history (4)
6. This man and woman are ___ (8) 
9. This symbol indicates a ___ (11) 
11. The shaded symbol represents the patient's maternal ___ (4) 
12. Also called 'changes' or 'alterations'; these can be beneficial, harmful or neutral (9)
13. This person is ___ (8) 
15. This individual is ___ (8) 
16. Identifying which people are affected with a condition in a family helps to recognise a ___ of inheritance (7)
18. Used to indicate the patient/person providing information for a pedigree (5)

And for a bonus point: Use the letters in the coloured squares to complete the following sentence:

Pedigree symbols have been agreed internationally and ___ (12), so that any health professional can look at a patient's family history and quickly appreciate key information.

Family history puzzle answers

Across

1. pedigree
5. genetic
7. pregnancy
8. rapport
10. first cousins
14. siblings
17. identical
19. three
20. divorced
21. DNA

Down

2. diagnosis
3. unknown
4. risk
6. partners
9. miscarriage
11. aunt
12. mutations
13. affected
15. deceased
16. pattern
18. arrow

Bonus answer: standardised

Cancer scenarios

Taking a family history can enable you to discuss with the patient and family the possibility of a genetic basis to their diagnosis. Patients are often concerned at the possible implications for other family members.

Scenario 1

John is talking to the practice nurse about his concerns because bowel cancer runs in his family. Following the drawing of a family history it can be seen why he is concerned.

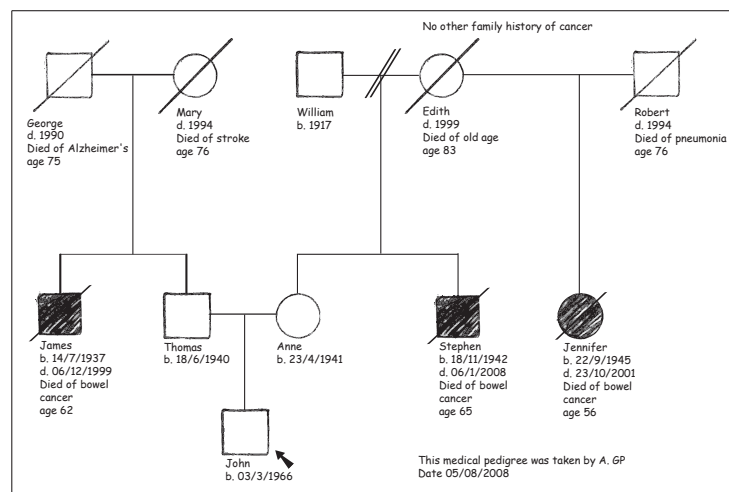

Fig. 1 Scenario 1

Three family members have died of bowel cancer. It would be important to identify the site of these cancers to see if they are indeed the same, which would increase the chance that these are due to the same genetic condition.

However, the three people are not related to one another as first degree family members e.g. parent or full sibling. And there is no evidence of cancer in the closer relatives, or in other generations, which might suggest an increased genetic risk. This pedigree (Fig. 1) therefore demonstrates the importance of considering three generations within a family history. Using the UK National Guidelines, John's risk would be considered low and whilst he may be offered advice and monitoring, unless symptomatic it would be unlikely he would be offered any invasive screening techniques.

Scenario 2

Jane is attending the oncology clinic as she has found a breast lump. She talks to you about her fears for her two young daughters as there seems to be so much cancer in the family.

You suggest drawing a family pedigree; an example of this pedigree can be found on the next page (Fig. 2).

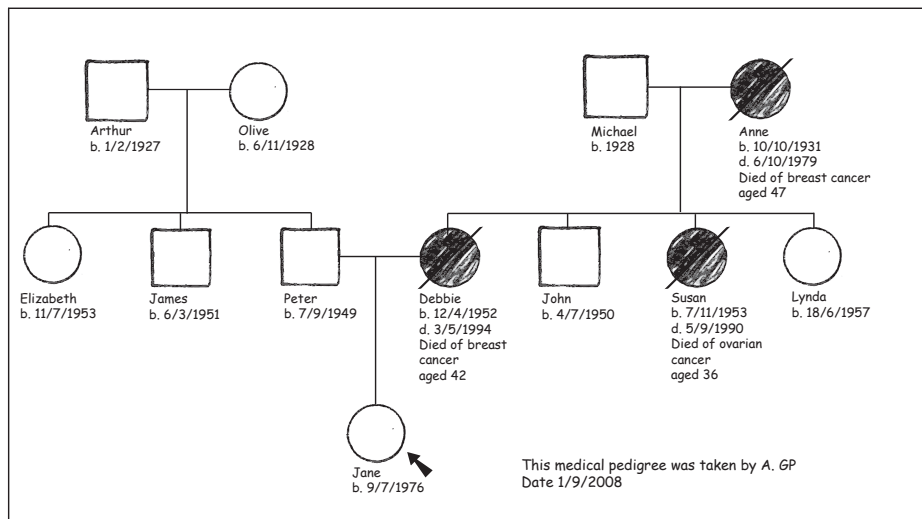

Fig. 2 Scenario 2

On taking a genetic family history it is clear that there is a possible pattern within her family. You discuss that whilst you could give her a probability of there being a genetic predisposition in the family based on published information obtained from studies of many families, it is impossible to say there is a definitive genetic cause without further investigations.

If following her biopsy breast cancer is diagnosed, you would want to discuss with Jane the services available for genetic investigations and the way that referrals are made.

learning
genetics
teaching
education
resources
clinical health
practice

www.geneticseducation.nhs.uk

